



## DESCRIPTION

The PM110 series of compact, open PCB constructed, AC-DC switching power supplies are specially designed for medical applications. They are capable of delivering 72 to 110 watts of continuous power at 25 CFM forced air cooling or 80 watts at convection cooling. They operate at 85 to 264VAC input voltage without the need of changing jumper. All models meet the safety requirements of UL, CSA and IEC for non-patient contact medical equipment.

## FEATURES

- Low safety ground leakage current
- Meet EN55011 and FCC Class B
- Small size, light weigh
- 100% burn-in
- Wide input range 85 to 264VAC
- Input surge current protection
- Overvoltage protection
- Overcurrent protection
- Compliant with RoHS requirements

## INPUT SPECIFICATIONS

**Input voltage :** 85 to 264VAC  
**Input frequency :** 47 to 63Hz  
**Input current :** 3.20A (rms) for 115VAC  
 1.80A (rms) for 230VAC  
**Earth leakage current :** 90uA max. @ 115VAC, 60Hz  
 150uA max. @ 230VAC, 50Hz

## OUTPUT SPECIFICATIONS

**Output voltage/current :** See rating chart  
**Total output power :** 110 watts maximum at 25 CFM forced air cooling or 80 watts maximum at convection cooling  
**Ripple and noise :** 1% peak to peak maximum  
**Overvoltage protection :** Provided on output #1 only; set at 112-132% of its nominal output voltage  
**Overcurrent protection :** All outputs protected to short circuit conditions  
**Temperature coefficient :** All outputs  $\pm 0.04\%$  / $^{\circ}\text{C}$  max.  
**Transient response :** Maximum excursion of 4% or better on all models, recovering to 1% of final value within 500us after a 25% step load change  
**PFD signal:** TTL logic high for normal operation and TTL logic low upon loss of input power. This signal appears at least 1ms prior to +5V output dropping 5% below its nominal value. This signal also provides a minimum delay of 100ms after +5V is within regulation

## PM110 SERIES



## Safety Standard Approvals :

-  **UL 2601-1**  
File No. E178020
-  **CSA C22.2 No. 601.1**  
File No. LR93632
-  **TÜV EN60601-1**

## ENVIRONMENTAL SPECIFICATIONS

**Operating temperature:** 0 $^{\circ}\text{C}$  to +70 $^{\circ}\text{C}$   
**Storage temperature:** -40 $^{\circ}\text{C}$  to +85 $^{\circ}\text{C}$   
**Relative humidity :** 5% to 95% non-condensing  
**Derating:** Derate from 100% at +50 $^{\circ}\text{C}$  linearly to 50% at +70  
**Cooling :** 110 watts continuous output power at 25 CFM forced air cooling or 80 watts at convection cooling

## GENERAL SPECIFICATIONS

**Switching frequency:** 20KHz to 250KHz, varies with load and line  
**Efficiency :** 70% minimum on single output models with  $V_o \geq 12\text{V}$ , 65% minimum on the others  
**Hold-up time :** 12 msec minimum at 110VAC  
**Line regulation :**  $\pm 0.5\%$  maximum at full load  
**Inrush current :** 15 amps @ 115VAC or 30 amps @ 230VAC at 25 $^{\circ}\text{C}$  cold start  
**Withstand voltage :** 4000VAC from input to output  
 1500VAC from input to ground  
 500VAC from output to ground  
**MTBF :** 400,000 hours minimum at full load at 25 $^{\circ}\text{C}$  ambient, calculated per MIL-HDBK-217F, excluding DC fan.  
**EMC Performance (EN60601-1-2: 2001)**  
**EN55011:** Class B conducted, Class B radiated  
**FCC:** Class B conducted, Class B radiated  
**VCCI:** Class B conducted, Class B radiated  
**EN61000-3-2:** Harmonic distortion, Class A  
**EN61000-3-3:** Line flicker  
**EN61000-4-2:** ESD,  $\pm 8\text{KV}$  air and  $\pm 6\text{KV}$  contact  
**EN61000-4-3:** Radiated immunity, 3V/m for 80~2500MHz  
**EN61000-4-4:** Fast transient/burst,  $\pm 2\text{KV}$   
**EN61000-4-5:** Surge,  $\pm 1\text{KV}$  diff.,  $\pm 2\text{KV}$  com.  
**EN61000-4-6:** Conducted immunity, 3Vrms  
**EN61000-4-8:** Magnetic field immunity, 3A/m  
**EN61000-4-11:** Voltage dips, 30% reduction for 500ms, 60% reduction for 100ms and >95% reduction for 10ms

# UNIVERSAL INPUT

# PM110 MEDICAL SERIES

## OUTPUT VOLTAGE/ CURRENT RATING CHART

(3)(4) MODEL	Output #1				Output #2 Ipeak				Output #3				Output #4				Maximum Output Power (2)	
	Vnom.	Imin.	Imax.	Tol.	Vnom.	Imin.	Imax.	(1) Tol.	Vnom.	Imin.	Imax.	Tol.	Vnom.	Imin.	Imax.	Tol.		
PM110-10-1A	3.3V	0A	22A	3%	(N/A)				(N/A)				(N/A)				72W	
PM110-10A	5.0V	0A	22A	3%	(N/A)				(N/A)				(N/A)				110W	
PM110-12A	12V	0A	9.0A	2%	(N/A)				(N/A)				(N/A)				110W	
PM110-13A	15V	0A	7.5A	2%	(N/A)				(N/A)				(N/A)				110W	
PM110-14A	24V	0A	4.5A	2%	(N/A)				(N/A)				(N/A)				110W	
PM110-16A	30V	0A	3.6A	2%	(N/A)				(N/A)				(N/A)				110W	
PM110-23A	+5.1V	0A	10A	3%	+12V	0A	5A	9.0A	3%	(N/A)			(N/A)				110W	
PM110-31A	+5.1V	0A	10A	3%	+12V	0A	5A	9.0A	3%	-12V	0A	1A	4%	(N/A)			110W	
PM110-32A	+5.1V	0A	10A	3%	+15V	0A	4A	7.5A	3%	-15V	0A	1A	4%	(N/A)			110W	
PM110-40A	+5.1V	0A	10A	3%	+12V	0A	5A	9.0A	3%	-12V	0A	1A	4%	-5V	0A	1A	4%	110W
PM110-41A	+5.1V	0A	10A	3%	+15V	0A	4A	7.5A	3%	-15V	0A	1A	4%	+24V	0A	1A	4%	110W
PM110-42A	+5.1V	0A	10A	3%	+12V	0A	5A	9.0A	3%	-12V	0A	1A	4%	+12V	0A	1A	4%	110W
PM110-45A	+5.1V	0A	10A	3%	+12V	0A	5A	9.0A	3%	-12V	0A	1A	4%	+24V	0A	1A	4%	110W
PM110-45-1A	+5.1V	2A	10A	3%	+12V	0A	5A	9.0A	3%	-12V	0A	1A	4%	+24V	1.5A	3A	10%	110W
PM110-45-2A	+5.1V	0A	10A	3%	+24V	0A	3A	5.0A	3%	-12V	0A	1A	4%	+12V	0A	1A	4%	110W
PM110-46A	+5.1V	0A	10A	3%	+15V	0A	4A	7.5A	3%	-15V	0A	1A	4%	-5V	0A	1A	4%	110W

- NOTES:
1. Peak output current with 10% maximum duty cycle for less than 60 seconds. Total peak power must not exceed 130 watts.
  2. 110 watts maximum at 25 CFM forced air cooling or 80 watts maximum at convection cooling, except model PM110-10-1A which is rated maximum 60 watts at convection cooling or 72 watts at 25 CFM forced air cooling.
  3. Safety agency approvals are for the above listed models in PCB format. To order models with metallic L-bracket or box, change suffix "A" to "B" for L-bracket format, to "C" for enclosed format (mechanical details shown in [page 7-2](#)), e.g. PM110-14C.
  4. The output #1 of model PM110-45-1A needs a minimum current of 2A to support the other outputs at their maximum rated loads.

## MECHANICAL SPECIFICATIONS

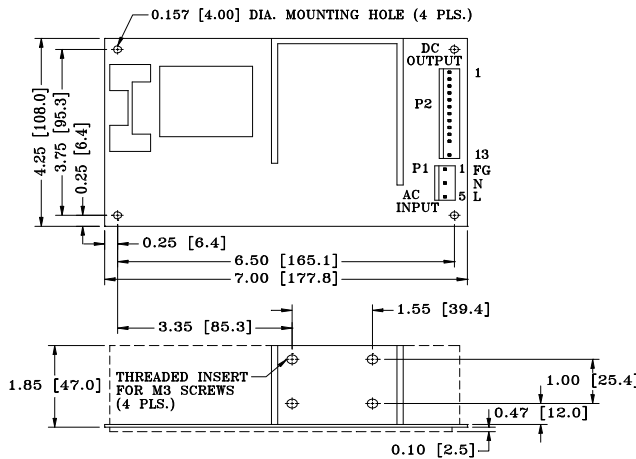

NOTES:

1. Dimensions shown in inch [mm]
2. Tolerance 0.02 [0.5] maximum
3. Input connector mates with Molex housing 09-50-3051 and Molex 2878 series crimp terminal.
4. Output connector mates with Molex housing 09-50-3131 and Molex 2878 series crimp terminal.
5. Weight: 640 grams (PCB format)
6. The copper pad of the mounting hole near P1 is for system grounding through a metallic stand-off to system chassis.

## PIN CHART

MODEL	PIN	1, 2, 3	4, 5	6, 7	8, 9	10	11	12	13
PM110-10-1A PM110-12A PM110-13A PM110-14A	PM110-10A PM110-13A PM110-16A	OUTPUT #1	RETURN	RETURN	OUTPUT #1	P.F.D	N.C.	KEY	N.C.
PM110-23A		OUTPUT #1	COMMON RETURN	COMMON RETURN	OUTPUT #2	P.F.D	N.C.	KEY	N.C.
PM110-31A	PM110-32A	OUTPUT #1	COMMON RETURN	COMMON RETURN	OUTPUT #2	P.F.D	OUTPUT #3	KEY	N.C.
PM110-40A PM110-42A PM110-45-1A PM110-46A	PM110-41A PM110-45A PM110-45-2A	OUTPUT #1	COMMON RETURN	COMMON RETURN	OUTPUT #2	P.F.D	OUTPUT #3	KEY	OUTPUT #4