

V4-1W Series

1W Regulated Single output



Features

- 7 Pin SIL / 14 Pin DIL Package
- 1000 VDC Isolation
- Up to 3000 VDC Isolation
- Low Ripple and Noise
- Efficiency up to 68%
- -40 ~ 85°C Operation Temperature Range
- Non-Conductive Black Plastic Case



The V4 series is a family of cost effective 1W single output DC-DC converters. These converters achieve low cost and ultra-miniature SIP 7 pin or DIP 14 pin size. Devices are encapsulated using flame retardant resin. The models operate from input voltage of 5, 12, 24 Vdc with output voltage of 3.3, 5, 7.2, 9, 12, 15Vdc. High performance features include 1000Vdc~3000Vdc input/output isolation, high efficiency operation and output voltage accuracy of $\pm 2\%$ maximum. Standard features include an input range of $\pm 10\%$ tolerance and low output noise and ripple.

All specifications typical at $T_a=25^\circ\text{C}$, nominal input voltage and full load unless otherwise specified

OUTPUT SPECIFICATIONS	
Voltage accuracy	$\pm 2\%$
Line regulation	$\pm 0.5\%$
Load regulation	(From 0% to 100% Load) $\pm 0.5\%$ (Output 3.3V Model) $\pm 1.0\%$
Ripple & noise(20 MHz bandwidth)(1)	50mV pk-pk
Temperature coefficient	$\pm 0.02\%/^\circ\text{C}$
Capacitor load(2)	See table

INPUT SPECIFICATIONS	
Voltage Range	$\pm 10\%$
Max. Input Current	See table
No-Load Input Current	See table
Input Filter	Capacitors
Input Reflected Ripple Current(3)	20mA pk-pk

GENERAL SPECIFICATIONS	
Efficiency	See table
I/O Isolation Voltage(3 sec)	
Input/Output	1000~3000Vdc
I/O Isolation Capacitance	60 pF Typ.
I/O Isolation Resistance	1000M Ohm
Switching Frequency	Variable 50kHz
Humidity	95% rel H
Reliability Calculated MTBF(MIL-HDBK-217 F)	>4.261 Mhrs
Safety Standard : (designed to meet)	IEC 60950-1

PHYSICAL SPECIFICATIONS	
Case Material	Non-conductive Black Plastic(UL94V-0 rated)
Pin Material	0.5mm Alloy42 Solder-coated
Potting Material	Epoxy (UL94V-0 rated)
Weight	2.7g
Dimensions	SIP Case 0.76"x0.28"x0.39" DIP Case 0.80"x0.40"x0.27"

ENVIRONMENT SPECIFICATIONS	
Operating Temperature	$-40^\circ\text{C} \sim 85^\circ\text{C}$ (See Derating Curve)
Maximum Case Temperature	100°C
Storage Temperature	$-40^\circ\text{C} \sim 125^\circ\text{C}$
Cooling	Nature Convection

ABSOLUTE MAXIMUM RATINGS(4)	
These are stress ratings. Exposure of devices to any of these conditions may adversely affect long-term reliability.	
Input Voltage(100mS)	
5 Modes	0~7 Vdc
12 Modes	0~15 Vdc
24 Modes	0~28 Vdc
Lead Soldering Temperature	260°C
(1.5mm from case 10sec.)	

The information and specifications contained in this data sheet are believed to be correct at time of publication. However, MOTIEN Technologies accepts no responsibility for consequences arising from printing errors or inaccuracies. Specifications are subject to change without notice. No rights under any patent accompany the sale of any such product(s) or information contained herein.

V4 - 1W Regulated Single output

PARTNUMBER STRUCTURE

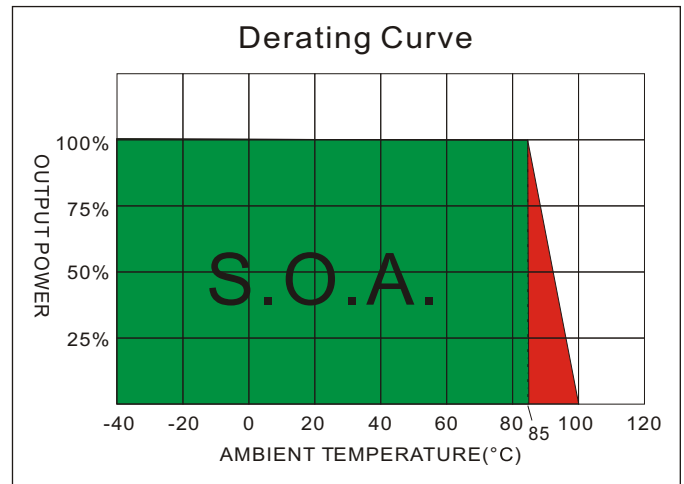
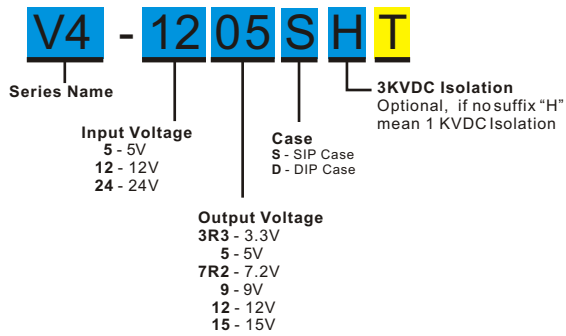

MODEL SELECTION GUIDE

MODEL NUMBER	INPUT Voltage Range (Vdc)	INPUT Current		OUTPUT Voltage (Vdc)	OUTPUT Current Full load (mA)	EFFICIENCY @FL(%)	Capacitor Load(uF)
		No-Load (mA)	Full Load (mA)				
V4-053R3ST	5	30	385	3.3	333	57	220
V4-0505ST	5	30	307	5	200	65	220
V4-057R2ST	5	30	307	7.2	138.9	65	220
V4-0509ST	5	35	307	9	111.1	65	220
V4-0512ST	5	35	294	12	83.3	68	220
V4-0515ST	5	35	294	15	66.7	68	220
V4-123R3ST	12	20	160	3.3	333	57	220
V4-1205ST	12	20	132	5	200	63	220
V4-127R2ST	12	20	128	7.2	138.9	65	220
V4-1209ST	12	20	126	9	111.1	66	220
V4-1212ST	12	20	122	12	83.3	68	220
V4-1215ST	12	20	126	15	66.7	66	220
V4-243R3ST	24	10	76	3.3	333	60	220
V4-2405ST	24	10	64	5	200	65	220
V4-247R2ST	24	10	64	7.2	138.9	65	220
V4-2409ST	24	10	61	9	111.1	68	220
V4-2412ST	24	10	61	12	83.3	68	220
V4-2415ST	24	10	61	15	66.7	68	220

Suffix "H" means 3 KVdc isolation

V4 - 1W Regulated Single output

MODEL NUMBER	INPUT Voltage Range (Vdc)	INPUT Current		OUTPUT Voltage (Vdc)	OUTPUT Current		EFFICIENCY @FL(%)	Capacitor Load(uF)
		No-Load (mA)	Full Load (mA)		Full load (mA)			
V4-053R3DT	5	30	350	3.3	333	57	220	
V4-0505DT	5	35	317	5	200	63	220	
V4-057R2DT	5	45	327	7.2	138.9	61	220	
V4-0509DT	5	40	298	9	111.1	67	220	
V4-0512DT	5	35	298	12	83.3	67	220	
V4-0515DT	5	35	298	15	66.7	67	220	
V4-123R3DT	12	20	146	3.3	333	57	220	
V4-1205DT	12	20	132	5	200	63	220	
V4-127R2DT	12	20	132	7.2	138.9	63	220	
V4-1209DT	12	20	128	9	111.1	65	220	
V4-1212DT	12	20	122	12	83.3	68	220	
V4-1215DT	12	20	126	15	66.7	66	220	
V4-243R3DT	24	10	73	3.3	333	57	220	
V4-2405DT	24	10	76	5	200	60	220	
V4-247R2DT	24	10	76	7.2	138.9	60	220	
V4-2409DT	24	10	61	9	111.1	68	220	
V4-2412DT	24	10	63	12	83.3	66	220	
V4-2415DT	24	10	63	15	66.7	66	220	

Suffix "H" means 3 KVdc isolation

NOTE

1. Ripple/Noise measured with 20MHz bandwidth.
2. Tested by minimal Vin and constant resistive load.
3. Measured Input reflected ripple current with a simulated source inductance of 12uH.
4. Exceeding the absolute ratings of the unit could cause damage. It is not allowed for continuous operating.
5. Operation under no-load conditions will not damage these devices, however they may not meet all listed specifications.

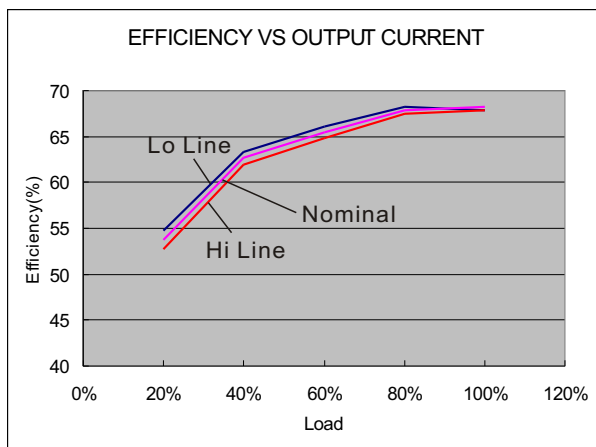

05 Models

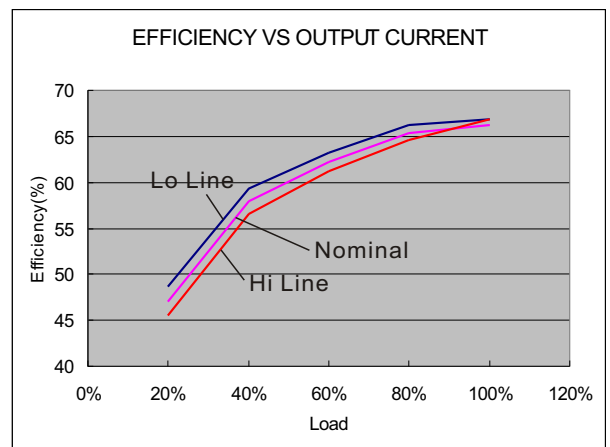

12 Models

V4 - 1W Regulated Single output

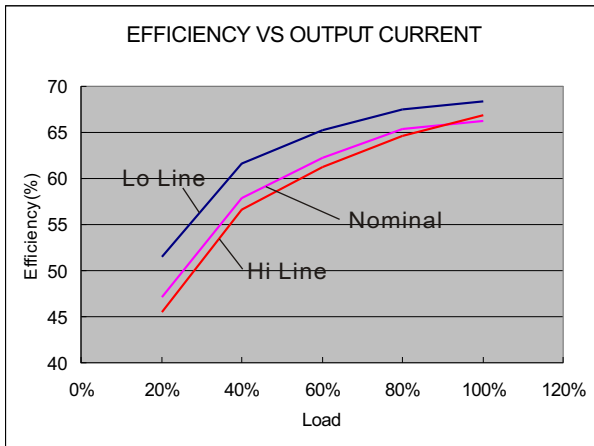

24 Models

MECHANICAL SPECIFICATIONS

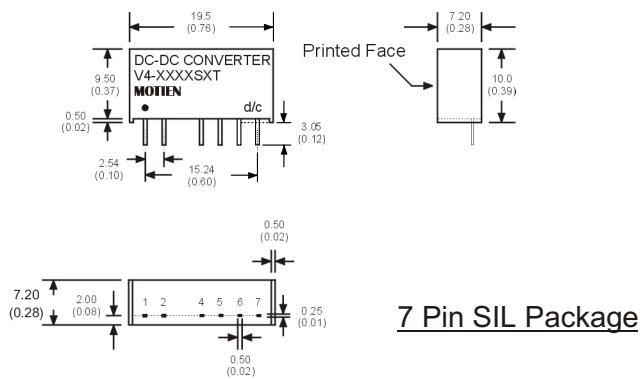

PIN CONNECTIONS		
PIN NUMBER	SINGLE	SINGLE-H
1	+V Input	+V Input
2	-V Input	-V Input
4	-V Output	N.P.
5	N.P.	-V Output
6	+V Output	N.P.
7	N.P.	+V Output

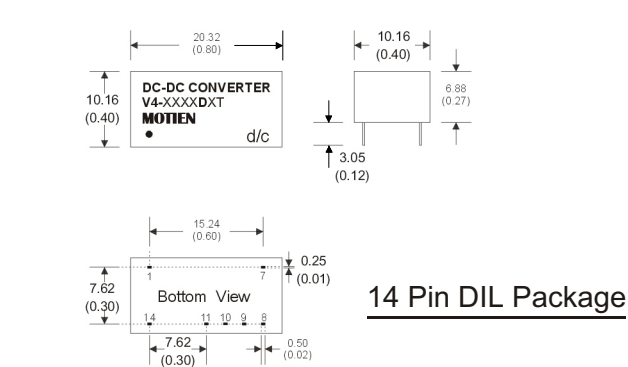

PIN CONNECTIONS		
PIN NUMBER	SINGLE	SINGLE-H
1	-V Input	-V Input
7	N.C.	N.C.
8	N.P.	+V Output
9	+V Output	N.P.
10	N.P.	-V Output
11	-V Output	N.P.
14	+V Input	+V Input

Notes : All dimensions are typical in millimeters (inches).
 1. Pin diameter: 0.5±0.05 (0.02±0.002)
 2. Pin pitch tolerance: ±0.35 (±0.014)
 3. Case Tolerance: ±0.5 (±0.02)