

# VF-2W Series

2W Regulated Single output



## Features

- 12 Pin SIL Package
- 1000 VDC Isolation
- Up to 3000 VDC Isolation
- Continuous Short Circuit Protection
- Efficiency up to 69%
- -25 ~ 71°C Operation Temperature Range

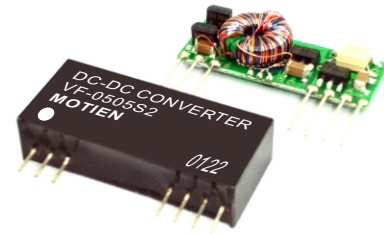

The VF series is a family of cost effective 2W single output DC-DC converters. These converters combine miniature package in a 12-pin SIL compatible case with high performance features such as 1000 VDC~3000 VDC input/output isolation voltage, continuous short circuit protection with automatic restart and tight line / load regulation. Devices are encapsulated using flame retardant resin. Input voltages of 5, 12, 24 with output voltage of 3.3, 5, 7.2, 9, 12, 15, 18, 24 Vdc. High performance features include high efficiency operation up to 69% and output voltage accuracy of  $\pm 2\%$  maximum. Standard features include an input range of  $\pm 10\%$  tolerance and low output noise and ripple.

All specifications typical at  $T_a = 25^\circ\text{C}$ , nominal input voltage and full load unless otherwise specified

OUTPUT SPECIFICATIONS	
Voltage accuracy	$\pm 2\%$
Line regulation	$\pm 0.5\%$
Load regulation	(From 0% to 100% Load) $\pm 0.5\%$ (Output 3.3V Model) $\pm 1.5\%$
Ripple & noise(20 MHz bandwidth)(1)	75mV pk-pk
Short Circuit Protection	Indefinite(Automatic Recovery)
Temperature coefficient	$\pm 0.02\%/^\circ\text{C}$
Capacitor load(2)	See table

INPUT SPECIFICATIONS	
Voltage Range	$\pm 10\%$
Max. Input Current	See table
No-Load Input Current	See table
Input Filter	Capacitor
Input Reflected Ripple Current(3)	20mA pk-pk

GENERAL SPECIFICATIONS	
Efficiency	See table
I/O Isolation Voltage(3 sec)	
Input/Output	1000~3000Vdc
I/O Isolation Capacitance	60 pF Typ.
I/O Isolation Resistance	1000M Ohm
Switching Frequency	50kHz typ
Humidity	95% rel H
Reliability Calculated MTBF(MIL-HDBK-217 F)	>1.12 Mhrs
Safety Standard : (designed to meet)	IEC 60950-1

PHYSICAL SPECIFICATIONS	
Case Material	Non-conductive Black Plastic(UL94V-0 rated)
Pin Material	0.5mm Alloy42 Solder-coated
Potting Material	Epoxy (UL94V-0 rated)
Weight	7.2g
Dimensions	1.26"x0.32"x0.57"

ENVIRONMENT SPECIFICATIONS	
Operating Temperature	$-25^\circ\text{C} \sim 71^\circ\text{C}$ (See Derating Curve)
Maximum Case Temperature	100°C
Storage Temperature	$-40^\circ\text{C} \sim 125^\circ\text{C}$
Cooling	Nature Convection

ABSOLUTE MAXIMUM RATINGS(4)	
These are stress ratings. Exposure of devices to any of these conditions may adversely affect long-term reliability.	
Input Voltage(100mS)	
5 Modes	0~7 Vdc
12 Modes	0~15 Vdc
24 Modes	0~28 Vdc
Lead Soldering Temperature	260°C
(1.5mm from case 10sec.)	

The information and specifications contained in this data sheet are believed to be correct at time of publication. However, MOTIEN Technologies accepts no responsibility for consequences arising from printing errors or inaccuracies. Specifications are subject to change without notice. No rights under any patent accompany the sale of any such product(s) or information contained herein.

## VF - 2W Regulated Single output

### PARTNUMBER STRUCTURE

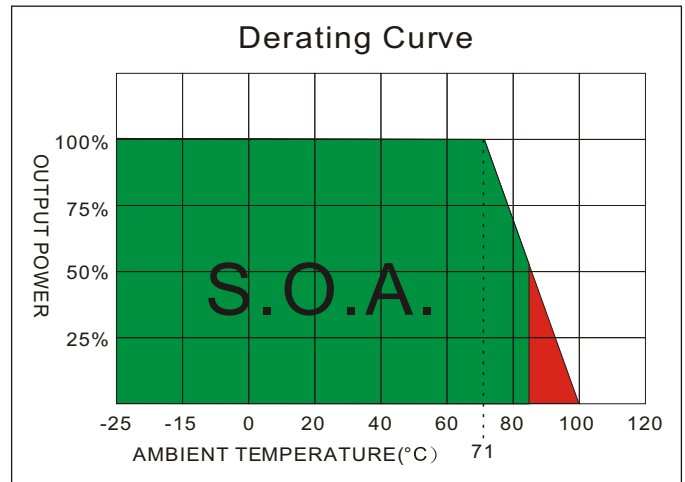
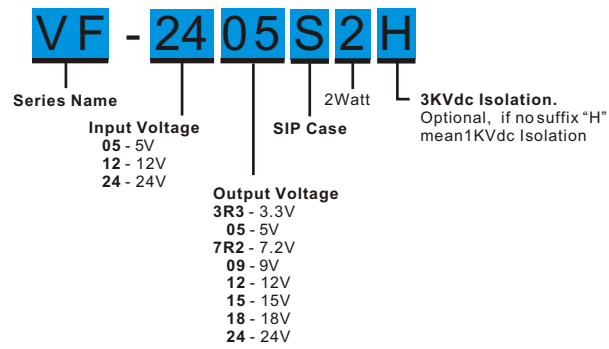

## MODEL SELECTION GUIDE

MODEL NUMBER	INPUT Voltage Range (Vdc)	INPUT Current		OUTPUT Voltage (Vdc)	OUTPUT Current Full load (mA)	EFFICIENCY @FL(%)	Capacitor Load(µF)
		No-Load (mA)	Full Load (mA)				
VF-053R3S2	5	70	515	3.3	500	64	330
VF-0505S2	5	70	606	5	400	66	330
VF-057R2S2	5	70	606	7.2	277.7	66	330
VF-0509S2	5	70	597	9	222.2	67	330
VF-0512S2	5	80	597	12	166.6	67	330
VF-0515S2	5	80	597	15	133.3	67	330
VF-0518S2	5	80	597	18	111.1	67	330
VF-0524S2	5	80	579	24	83.3	69	330
VF-123R3S2	12	30	214	3.3	500	64	330
VF-1205S2	12	30	252	5	400	66	330
VF-127R2S2	12	30	252	7.2	277.7	66	330
VF-1209S2	12	45	248	9	222.2	67	330
VF-1212S2	12	45	248	12	166.6	67	330
VF-1215S2	12	45	248	15	133.3	67	330
VF-1218S2	12	50	245	18	111.1	68	330
VF-1224S2	12	50	245	24	83.37	68	330
VF-243R3S2	24	25	107	3.3	500	64	330
VF-2405S2	24	25	124	5	400	67	330
VF-247R2S2	24	25	124	7.2	277.7	67	330
VF-2409S2	24	25	122	9	222.2	68	330
VF-2412S2	24	25	122	12	166.6	68	330
VF-2415S2	24	25	122	15	133.3	68	330
VF-2418S2	24	25	120	18	111.1	69	330
VF-2424S2	24	25	120	24	83.3	69	330

Suffix "H" means 3KVdc isolation

### NOTE

1. Ripple/Noise measured with 20MHz bandwidth.
2. Tested by minimal Vin and constant resistive load.
3. Measured Input reflected ripple current with a simulated source inductance of 12µH.
4. Exceeding the absolute ratings of the unit could cause damage. It is not allowed for continuous operating.
5. Operation under no-load conditions will not damage these devices, however they may not meet all listed specifications.

The models listed above is just for standard type. If you need the special specification product, please contact our service member by telephone presented in shortform cover or e-mail to : sales@motien.com.tw

# VF - 2W Regulated Single output

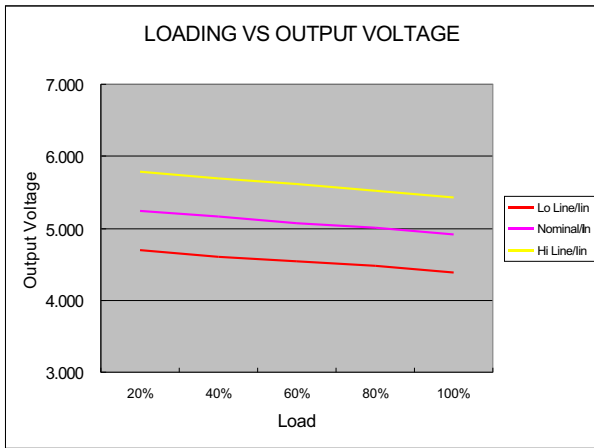

05 Models

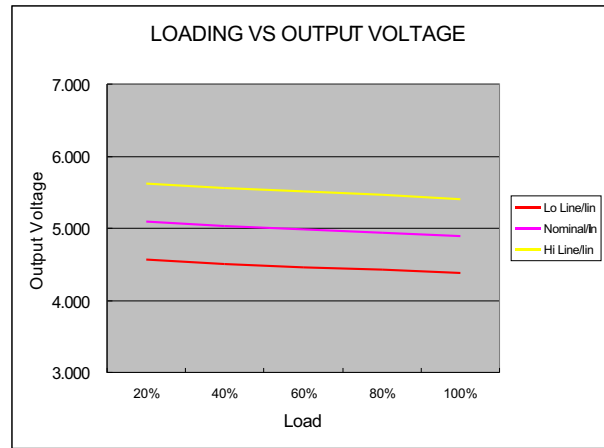

12 Models

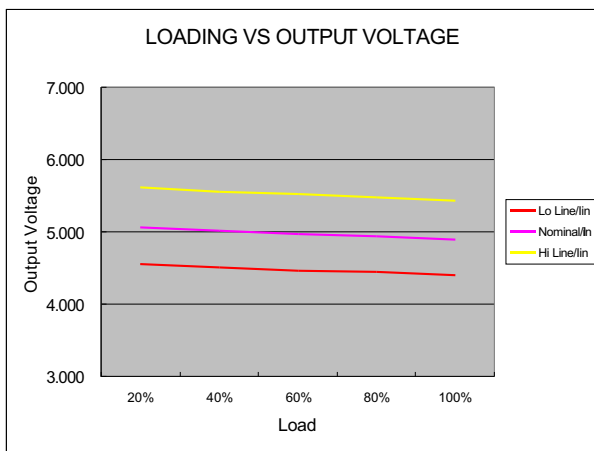

24 Models

## MECHANICAL SPECIFICATIONS

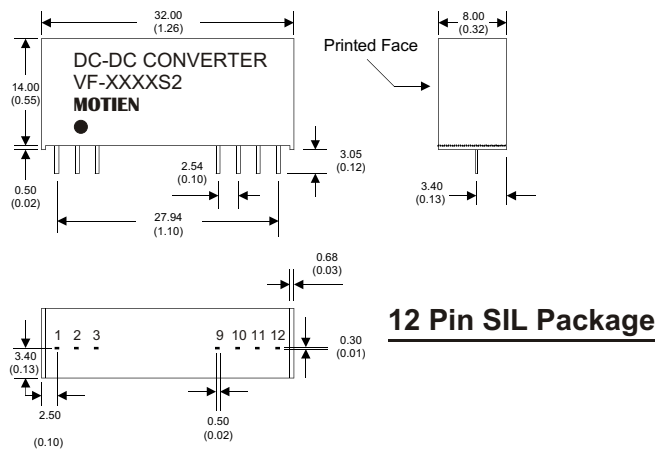

**12 Pin SIL Package**

- Notes : All dimensions are typical in millimeters ( inches ).
1. Pin diameter:  $0.5 \pm 0.05$  (  $0.02 \pm 0.002$  )
  2. Pin pitch tolerance:  $\pm 0.35$  (  $\pm 0.014$  )
  3. Case Tolerance:  $\pm 0.5$  (  $\pm 0.02$  )

PIN CONNECTIONS		
PIN NUMBER	SINGLE	SINGLE-H
1	+V Input	+V Input
2	N.C.	-V Input
3	N.C.	N.C.
9	N.C.	N.C.
10	-V Output	-V Output
11	+V Output	+V Output
12	-V Input	N.C.